

LIVE LAB 4-8 (FHD Live Production Lab)

LAB SPECIFICATIONS

- (4-8) GV LDX 3G Cameras w/ 2" viewfinders
- (4-8) GV LDK 3G Fiber/Triax Base Stations
- (4-8) GV OCP 400 Operator Control Panels

Optional Camera Equipment:

- Panasonic AW HE120 PTZ Camera w/ SM Fiber Transmission Control
- Sony PTZ Camera Systems
- Marshall POV Camera Systems
- GV LDK 4426 Single Mode Fiber to Triax
- GV LDK Super Xpander w/ 7" LCD Color VF
- Fujinon 12x, 18x, 22x, 42x, 72x, 99x & 107x Zoom Lenses
- Vinten Vector 750 Pan Heads w/ Tripods
- Vinten Pro Peds w/ Vector 750 Pan Head
- Cartoni Gamma Pan Handheld Heads w Tripods
- AB On-Air 512 RF Wireless Camera Systems
- Studio Build-up Kits

SWITCHING & EFFECTS

- FOR-A HVS 490 3G Digital Switcher
- 2 Mix Effects bank w/ 32 Inputs, 16 Outputs
- Frame Sync on every Input
- 4 Keyers per ME, 4 Floating Keyers
- 4 Chroma Keyers per ME
- 4 Color Correctors per ME
- 4 Still/Clip Stores
- 100 Registers of Control Panel Configurations
- 4 Channels of IPDM per ME
- 3 Internal Multiviewers w/ up to 16 Picture-in-Picture Displays

RECORDING & PLAYBACK

Optional Recording Equipment:

- EVS LSM Server - 6Ch/8Ch/12Ch
- EVS X-File
- EVS IP Director
- SAN File Storage
- Gig & 10GB Ethernet Switches
- ENVIVO Studio, Replay or Review 8Ch Video Servers
- USB Recorder/Streaming Encoder/Duplicator
- AJA KiPro/KiPro Ultra Plus Recorder
- LYON CLOUD File and Live Stream Transfer

GRAPHICS

Optional Graphics Equipment:

- Chyron Hyper X3, Mosaic, Ross Xpressions, VizRT, ProPresenter
- FOR-A Telestrator
- Clock & Score Box

TERMINAL EQUIPMENT

- Ross Ultrix 48x48 Router w/ Embedding, Multi-viewer, Frame Sync, MADI
- Evertz 5601 MSC 3G Master Sync Generator
- Leader, Textronics Rasterizers
- Hitomi VALID Generator
- AJA FS2 Frame Synchronizer/Cross Converter

Optional Terminal Equipment:

- FS2, FS3, FS4 or FS HDR Processor
- FOR-A FA505 5Ch Color Corrector
- HD/SDI to DVI or HDMI Converter
- HDMI to HD/SDI Converter
- HD/SDI Fiber Converter
- Ethernet Media Converter
- 12Ch and 16Ch 3G Video Mux
- HD Demodulator

COMMUNICATIONS

- RTS Zeus III Matrix Intercom 32 x 32
- RTS KP 32 & KP 12 Intercom Stations
- (2) 2-Wire Powered Intercom Channels
- (4) Powered IFB Channels
- RTS 2-Wire Source Assign Panel 6/12, 9/12
- RTS BP325 Intercom Belt Packs
- RTS 4030 IBF Belt Packs
- Telex PH88 Lightweight Headsets
- Beyer DT108 Single Muff Headsets
- Beyer DT109 Dual Muff Headsets

Optional Communications Equipment:

- RTS TIF-2000 Telephone Interfaces
- Riedel Bolero Wireless Intercom
- Analog "QKT" Phone Couplers
- Motorola Two-Way Portable Radios

AUDIO

Optional Audio Consoles:

- Allen & Heath Avantis 64Ch/42 Bus Digital Audio Console
- Calrec Summa or Artemis Bluefin 2 Digital Audio Console
- Select Calrec IO - Dante, MADI, Analog, AES
- Wohler Speaker Stations

Audio Equipment Options:

- 360 DigiCart E
- CD Player
- Surround Sound Processors
- Tascam DA-6400 Multitrack Recorder

OUTBOARD MONITORING

Optional Outboard Monitoring Equipment:

- 50", 32", 15"-27" Desktop Sizes
- Hi-Res Quality Control Monitors
- Secure Monitor Floor Stands

*Additional Monitors Available

MICROPHONES

- Shure UHF Digital RF Kits
- Announcer Headsets
- Talkback Boxes
- Stereo Shotgun Microphones
- Shotgun Microphones
- Handheld Microphones
- Lavalier Microphones
- RF Reporter Systems
- Parabolic Dish Microphones

CONSOLE - WORKSTATIONS

Optional Workstations:

- WorkSpace by LYON Labs Custom Consoles
- 46"w x 31"d x 28"h Individual Work Consoles
- Optional Stand-Alone or Attached Consoles
- TD/Op/Video Audio Side Car
- Padded Roll-Around Adjustable Chairs

CABLE

- Triax Camera Cable
- Video Mults
- Bins - Single Audio Cable
- Bins - Single Coax Video Cable
- TAC-12 Fiber Cable
- TAC-6 Fiber Cable
- 6-Pair Audio Snake

Optional Cable:

- SMPTE Camera Cable
- DT-12 Audio Mult(s)

LIGHTING

Optional Lighting:

- LED Light Kits

POWER REQUIREMENTS

- Single Phase, 120 Volts, 3 - 20A Circuits

LIVE LAB 4-8 (FHD Live Production Lab)

WorkSpace

by LYON LABS

PRODUCTION FRONT BENCH CONSOLES (P1)

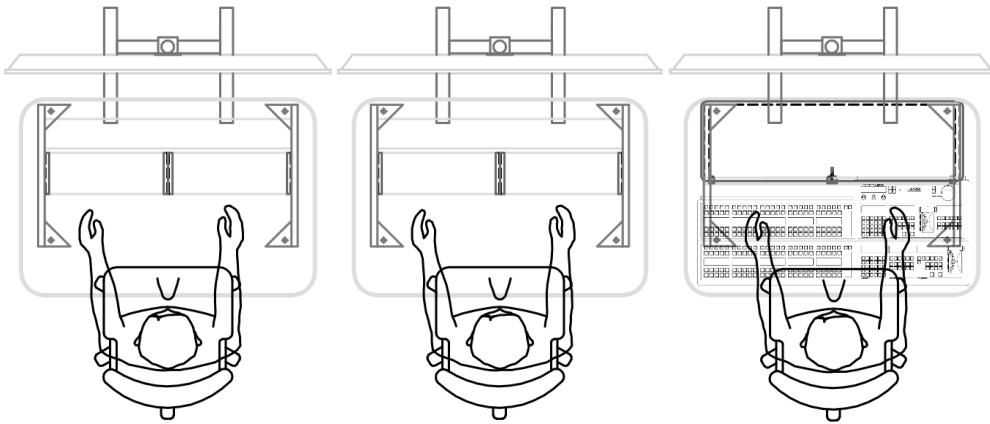

MIDDLE BENCH CONSOLES (P2)

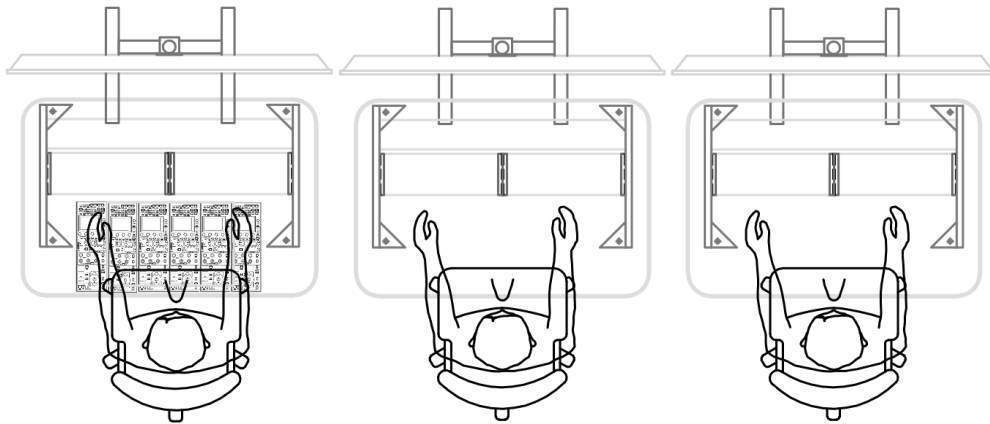

AUDIO CONSOLE (P3)

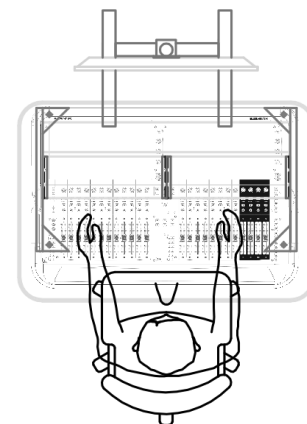

WorkSpace

by LYON LABS

► SPECIFICATIONS

- Customized production workflow options
- Individual consoles measure: 46"w x 31"d x 28" h
- Each bench be stand-alone or attached as a whole unit for better stability
- Optional console equipment include: KP Intercom Panel, Router Panel, Wohler and/or Power Strip
- Monitoring options include: 50", 32" 15" - 27" LCD Monitors, using secure floor stands
- All WorkSpace units come with padded roll-around Adjustable Chairs for crew comfort